

User's Manual

Model UT351-xA Digital Indicating Controller with Active Color PV Display and Embedded Ethernet User's Manual Installation



IM 05D01D13-01E

4th Edition: May 31, 2006

YOKOGAWA
Yokogawa Electric Corporation

This manual describes installation, wiring, and other tasks required to make the controller ready for operation.

Contents

1. Safety Precautions
2. Model and Suffix Codes
3. How to Install
4. How to Connect Wires
5. Hardware Specifications
6. Terminal Wiring Diagrams

Introduction

Thank you for purchasing the UT351 digital indicating controller. The controller is shipped from the factory with 4 hardcopy user's manuals (A2 and A3 size). The 4 user's manuals in hardcopy format describe the operating procedures required for basic use. It is recommended that you refer to these user's manuals to understand [1] installation, [2] initial settings, and [3] operating procedures of the controller. * "Ethernet" is registered trademark of XEROX Corporation.

How to Use the Manuals

Purpose	Manual Title	Description	Media
Setup	Installation	Describes the tasks (installation, wiring, and others) required to make the controller ready for operations.	A2-size paper, back and front
Basic operation	Initial Settings	Describes examples of setting PV input types, control output types, and alarm types. Making settings described herein allows you to carry out basic control.	A2-size paper, front
Operating procedures and troubleshooting	Operations	Describes key operation sequences. For operation control through external contact inputs, see the back of Installation User's Manual.	A2-size paper, back
Brief operation and setpoint recording	Parameters	Contains the parameter map used as a guideline for setting parameters and lists of parameters for recording User Settings.	A2-size paper, back and front
Basic operation of Active Color PV Display	Setting / Explanation of Active Color PV Display	Describes the setting/explanation of Active Color PV Display.	A3-size paper, back and front
Detailed description of functions	User's Manual (Reference)	Explains more advanced applications than those found in the 4 hardcopy user's manuals (A2 and A3 size).	CD-ROM

1. Safety Precautions

The following symbol is indicated on the controller to ensure safe use.

CAUTION

This symbol on the controller indicates that the operator must refer to an explanation in the user's manual in order to avoid the risk of injury or death of personnel or damage to the instrument. The manual describes how the operator should exercise special care to avoid electric shock or other dangers that may result in injury or loss of life.

The following symbols are used in the hardcopy user's manuals.

NOTE

Indicates that operating the hardware or software in a particular manner may damage it or result in a system failure.

IMPORTANT

Draws attention to information that is essential for understanding the operation and/or features of the controller.

Exemption from Responsibility

Make sure that all of the precautions are strictly adhered to. Yokogawa Electric Corporation assumes no liability for any damage resulting from use of the instrument in contradiction to the precautions. Also, Yokogawa Electric Corporation assumes no liability to any party for any loss or damage, direct or indirect, caused by the use of any unpredictable defect of the instrument.

Regarding Protection, Safety, and Prohibition Against Unauthorized Modification

- (1) In order to protect the product and the system controlled by it against damage and ensure its safe use, make certain that all of the instructions and precautions relating to safety contained in this document are strictly adhered to. Yokogawa does not guarantee safety if products are not handled according to these instructions.
- (2) Modification of the product is strictly prohibited.

2. Model and Suffix Codes

Before using the controller, check that the model and suffix codes match your order.

Model	Suffix Code	Description
UT351		Digital indicating controller (provided with retransmission output and 15 V DC loop power supply as standard)
Type	-0 -2	Standard type Heating/cooling type
Optional functions	A	With Ethernet communication

Check that the following items are provided:

- Digital indicating controller (of ordered model):
- Brackets (mounting hardware): 1 pair
- Unit label:
- User's Manuals: 3 (A2 size)
- User's Manuals "Setting/Explanation of Active Color PV Display": 1 (A3 size)
- User's Manuals (Reference) (CD-ROM version):

3. How to Install

NOTE

- To install the controller, select a location where:
- (1) no one may accidentally touch the terminals,
 - (2) mechanical vibrations are minimal,
 - (3) corrosive gas is minimal,
 - (4) temperature can be maintained at about 23°C and the fluctuation is minimal,
 - (5) no direct radiant heat is present,
 - (6) no magnetic disturbances are caused,
 - (7) no wind blows against the terminal board (reference junction compensation element),
 - (8) no water is splashed,
 - (9) no flammable materials are around,

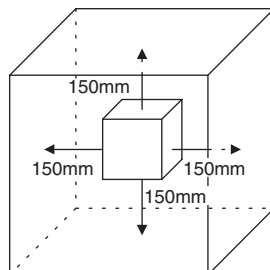

Never place the controller directly on flammable items or equipment. If the controller has to be installed close to flammable items or equipment, be sure to provide shielding panels all around the controller, at least 150mm away from every side; the panels should be made of either 1.43mm-thick metal-plated steel plates or 1.6mm-thick uncoated steel plates.

NOTE

Never touch the opening at the bottom of the case. It is to be used in the factory at shipping.

Installation Position

Install the controller at an angle within 30° from horizontal with the front panel facing upward. Do not install it facing downward. The position of right and left sides should be horizontal.

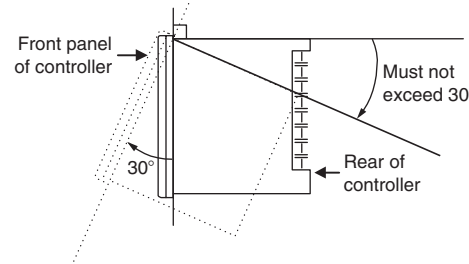

External Dimensions and Panel Cutout Dimensions

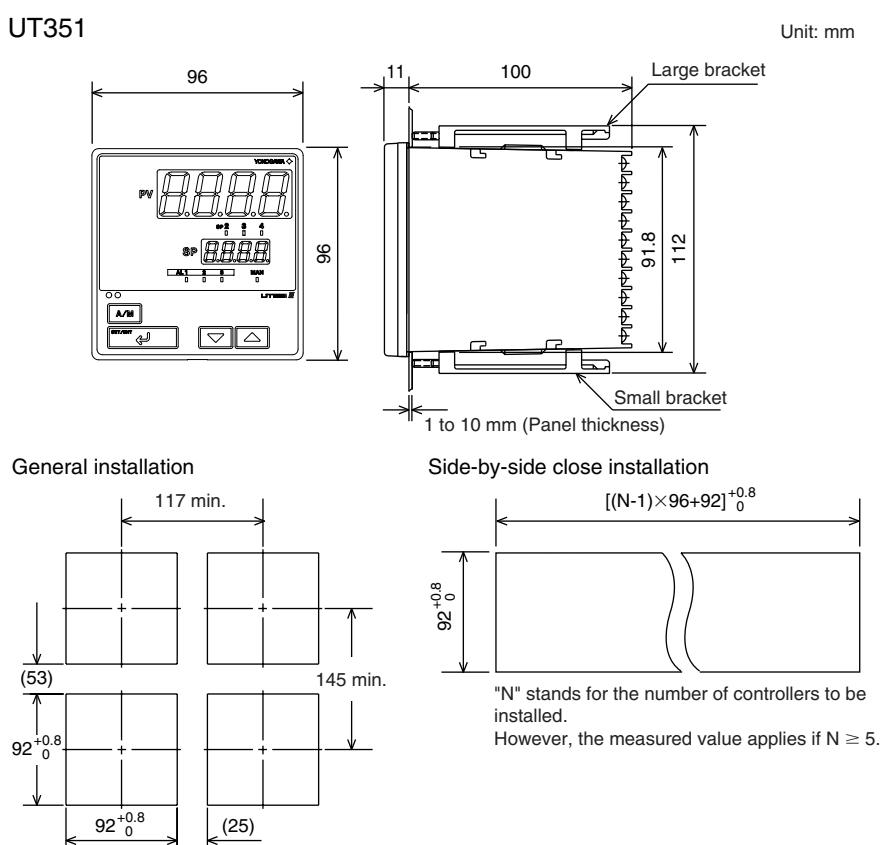

How to Install

CAUTION

Turn off the power to the controller before installing it on the panel because there is a possibility of electric shock.

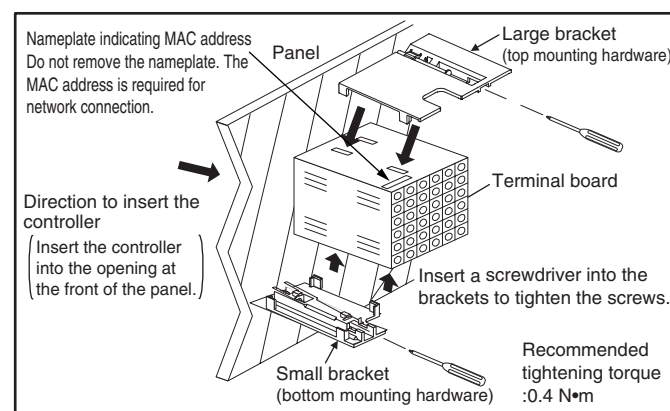

- After opening the mounting hole on the panel, follow the procedures below to install the controller:
1. Insert the controller into the opening from the front of the panel so that the terminal board on the rear is at the far side.
 2. Set the brackets in place on the top and bottom of the controller as shown in the figure on the left, then tighten the screws of the brackets. Take care not to over-tighten them.

4. How to Connect Wires

CAUTION

- 1) Before carrying out wiring, turn off the power to the controller and check that the cables to be connected are not alive with a tester or the like because there is a possibility of electric shock.
- 2) For the protection and safe use of the controller, be sure to place a circuit breaker (conforms with IEC60947, 5A, 100V or 220V AC) near the controller where the breaker can easily be operated. In addition, be sure to indicate that it is the instrument to cut the power supply of the controller.
- 3) Wiring must be carried out by personnel who have basic electrical knowledge and practical experience.

NOTE

- 1) Provide power from a single-phase instrument power supply. If there is a lot of noise in the power line, insert an insulating transformer into the primary side of the line and use a line filter (recommended part: ZAC2205-00U from TDK) on the secondary side. As a countermeasure against noise, do not place the primary and secondary power cables close to each other. For thermocouple input, use shielded compensating lead wires for wiring. For RTD input, use shielded wires that have low conductor resistance and cause no significant differences in resistance between the three wires. The cables to be used for wiring, terminal specifications, and recommended parts are as shown below.
- 3) Control output relays may be replaced. However, because they have a life of 100,000 times that of the resistance load, use auxiliary relays to turn on/off a load.
- 4) The use of inductance (L) loads such as auxiliary relays, motors and solenoid valves causes malfunction or relay failure; always insert a CR filter for use with alternating current or a diode for use with direct current, as a spark-removal surge suppression circuit, into the line in parallel with the load.
- 5) When there is a possibility of being struck by external lightning surge, use the arrester to protect the instrument.

For DC Relay Wiring

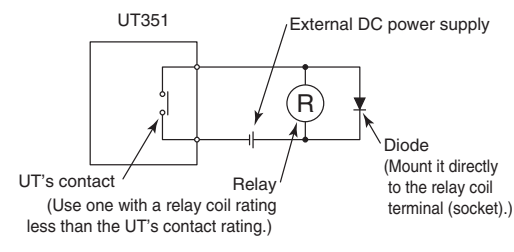

For AC Relay Wiring

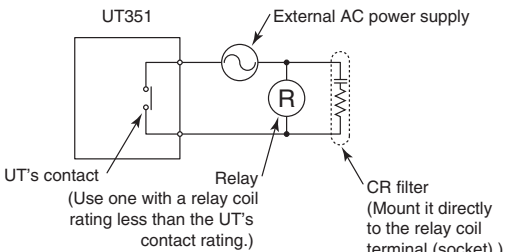

Cable Specifications and Recommended Cables

Purpose	Name and Manufacturer
Power supply, grounding, relay contact outputs	600 V PVC insulated wires, JIS C 3307, 0.9 to 2.0 mm ²
Thermocouple	Shielded compensating lead wires, JIS C 1610, □X-□-□-□ (See Yokogawa Electric's GS 6B1U1-E.)
RTD	Shielded wires (three conductors), UL2482 (Hitachi Cable)
Other signals	Shielded wires

Recommended Terminal Lugs

Applicable wire size	Tightening torque
0.3 to 1.65 mm ²	0.8 N·m or less

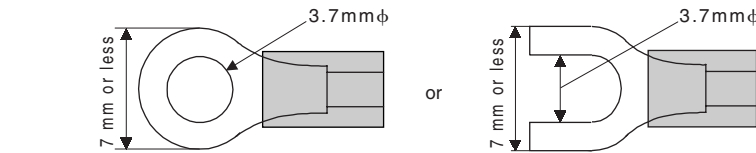

5. Hardware Specifications

PV Input Signals

- Number of inputs: 1 (terminals ①-②-③)
- Input type: Universal input system. The input type can be selected with the software.
- Sampling period: 250 ms
- Burnout detection: Functions at TC, RTD, standard signal (0.4 to 2 V or 1 to 5 V)
Upscale, downscale, and off can be specified. For standard signal, burnout is determined to have occurred if it is 0.1 V or less.
- Input bias current: 0.05 μA (for TC or RTD b-terminal)
- Measurement current (RTD): About 0.13 mA
- Input resistance: 1 MΩ or more for thermocouple or mV input About 1 MΩ for DC voltage input
- Allowable signal source resistance: 250 Ω or less for thermocouple or mV input
Effects of signal source resistance: 0.1 μV/Ω or less 2 kΩ or less for DC voltage input
Effects of signal source resistance: About 0.01%/100 Ω
- Allowable wiring resistance: for RTD input
Maximum 150 Ω/wire: Conductor resistance between three wires should be equal
However, 10 Ω/wire for a maximum range of -150.0 to 150.0°C.
Wire resistance effect: ±0.1°C /10 Ω
- Allowable input voltage: ±10 V DC for thermocouple, mV, or RTD input
- Allowable input voltage: ±20 V DC for DC voltage input
- Noise rejection ratio: 40 dB (50/60 Hz) or more in normal mode 120 dB (50/60 Hz) or more in common mode
- Reference junction compensation error: ±1.0°C (15 to 35°C) ±1.5°C (0 to 15°C, 35 to 40°C)
- Applicable standards: JIS, IEC, DIN (ITS-90) for thermocouples and RTD

Loop Power Supply

Supplies power to a two-wire transmitter. (15 V DC; terminals ③-④)
A resistor (10 to 250 Ω) connected between the controller and transmitter converts a current signal into a voltage signal, which is then read via the PV input terminal. Supply voltage: 14.5 to 18.0 V DC, max. 21 mA (provided with a protection circuit against a field short-circuit)

Retransmission Output

Either PV, target setpoint, or control output is output. Either the retransmission output or the 15 VDC loop power supply can be used with terminals ⑤-⑥.
• Number of outputs: 1 (terminals ⑤-⑥)
• Output signal: 4-20 mA DC
• Load resistance: 600 Ω or less
• Output accuracy: ±0.3% of span under standard operating conditions (23 ±2°C, 55 ±10% RH, power frequency of 50/60 Hz)

Control Output

Universal output system. The output type can be selected with the software.

- Current output (Standard type: terminals ⑥-⑦; Heating side: terminals ⑥-⑦; Cooling side: terminals ⑥-⑦)

Number of outputs	1 or 2 (two for heating/cooling type), switched between a voltage pulse output and current output.
Output signal	4-20 mA DC
Load resistance	600 Ω or less
Output accuracy	±0.3% of span under standard operating conditions (23 ±2°C, 55 ±10% RH, power frequency of 50/60 Hz)

- Voltage pulse output (Standard type: terminals ⑥-⑦; Heating side: terminals ⑥-⑦; Cooling side: terminals ⑥-⑦)

Number of outputs	1 or 2 (two for heating/cooling type), switched between a voltage pulse output and current output.
Output signal	On-voltage = 12 V or more (load resistance: 600 Ω or more) Off-voltage = 0.1 V DC or less
Resolution	10 ms

- Relay contact output (Standard type: terminals ①-②-③; Heating side: terminals ①-②-③; Cooling side: terminals ①-②-③)

Number of outputs	1 or 2 (two for heating/cooling type)
Output signal	Three terminals (NC, NO, and common) / Two terminals
Contact rating	Terminals ①-②-③ 250 V AC or 30 V DC, 3 A (resistance load) Terminals ③-④-⑤ 240 V AC or 30 V DC, 1A (resistance load)
Resolution	10 ms

Contact Inputs

- Purpose: Selection between target setpoints or Auto/Man modes, or for other purposes
- Number of inputs: 2
- Input type: Non-voltage contact or transistor open collector input
- Input contact rating: 12 V DC, 10 mA or more
- On/off determination: For non-voltage contact input, contact resistance of 1 kΩ or less is determined as "on" and contact resistance of 20 kΩ or more as "off."
For transistor open collector input, input voltage of 2 V or less is determined as "on" and leakage current must not exceed 100 μA when "off."
- Minimum status detection hold time: About 1 second.

Contact Outputs

- Purpose: Alarm output, FAIL output, and others
- Number of outputs: 3
- Relay contact rating: 240 V AC/1 A or 30 V DC/1 A ; 1a (COM terminal is common), (FAIL output ; 1b)

Display Specifications

- PV display:
4-digit, 7-segment green or red LED display, character height of 20 mm
- Setpoint display: 4-digit, 7-segment red LED display, character height of 9.3 mm
- Status indicating lamps: LEDs

Safety and EMC Standards

- Safety: Complies with IEC/EN61010-1 (CE), approved by C22.2 No.61010-1, approved by UL508.
Installation category : CAT. II Pollution degree : 2 (IEC/EN61010-1, C22.2 No.61010-1)
Measurement category : I (CAT. I: IEC/EN61010-1)
Rated measurement input voltage : 10V DC max.(across terminals), 300V AC max.(across ground)
Rated transient overvoltage : 1500V (Note)
Note : It is a value on the safety standard which is assumed by IEC/EN61010-1 in Measurement category I, and is not the value which guarantees an apparatus performance.

CAUTION

This equipment has Measurement category I, therefore do not use the equipment for measurements within Measurement categories II, III and IV.

Measurement category	Description	Remarks
I	CAT. I For measurements performed on circuits not directly connected to MAINS.	
II	CAT. II For measurements performed on circuits directly connected to the low voltage installation.	Appliances, portable equipments, etc.
III	CAT. III For measurements performed in the building installation.	Distribution board, circuit breaker, etc.
IV	CAT. IV For measurements performed at the source of the low-voltage installation.	Overhead wire, cable at the source of the low-voltage systems, etc.

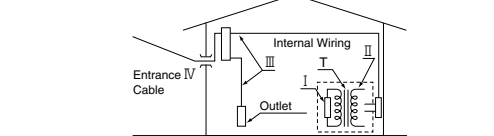

- EMC standards: Complies with EN61326, EN61000-3-2, EN61000-3-3 and EN55011 (CE), AS/NZS 2064 compliant (C-Tick), Class A Group 1. The instrument continues to operate at a measuring accuracy of within ±20% of the range during tests.

Construction, Installation, and Wiring

- Construction: Dust-proof and drip-proof front panel conforming to IP55.
- Installation: For side-by-side close installation the controller loses its dust-proof and drip-proof protection.
- Material: ABS resin and polycarbonate
- Case color: Black
- Weight: About 1 kg or less
- Dimensions: 96 (W) × 96 (H) × 100 (depth from panel face) mm
- Installation: Panel-mounting type. With top and bottom mounting hardware (1 each)
- Panel cutout dimensions: 92^{+0.8} (W) × 92^{+0.8} (H) mm
- Installation position: Up to 30° upward facing (not designed for facing downward)
- Wiring: M3.5 screw terminals (for signal wiring and power/ground wiring as well)

6. Terminal Wiring Diagrams

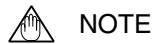

Do not use unassigned terminals as relay terminals.

UT351 Standard Type (Model UT351-0A) or Heating/Cooling type (Model UT351-2A)

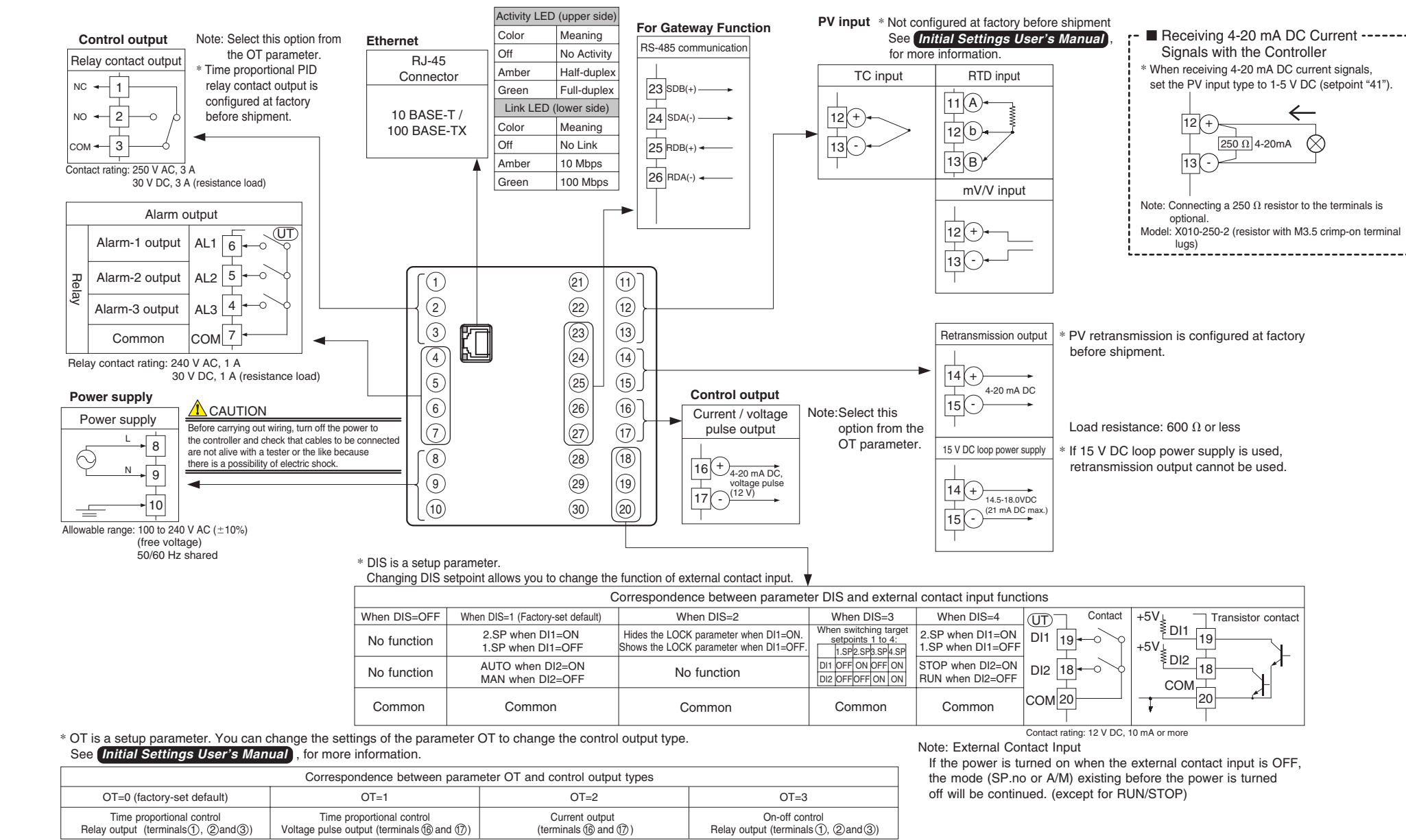

UT351 Heating/Cooling Type (Model UT351-2A)

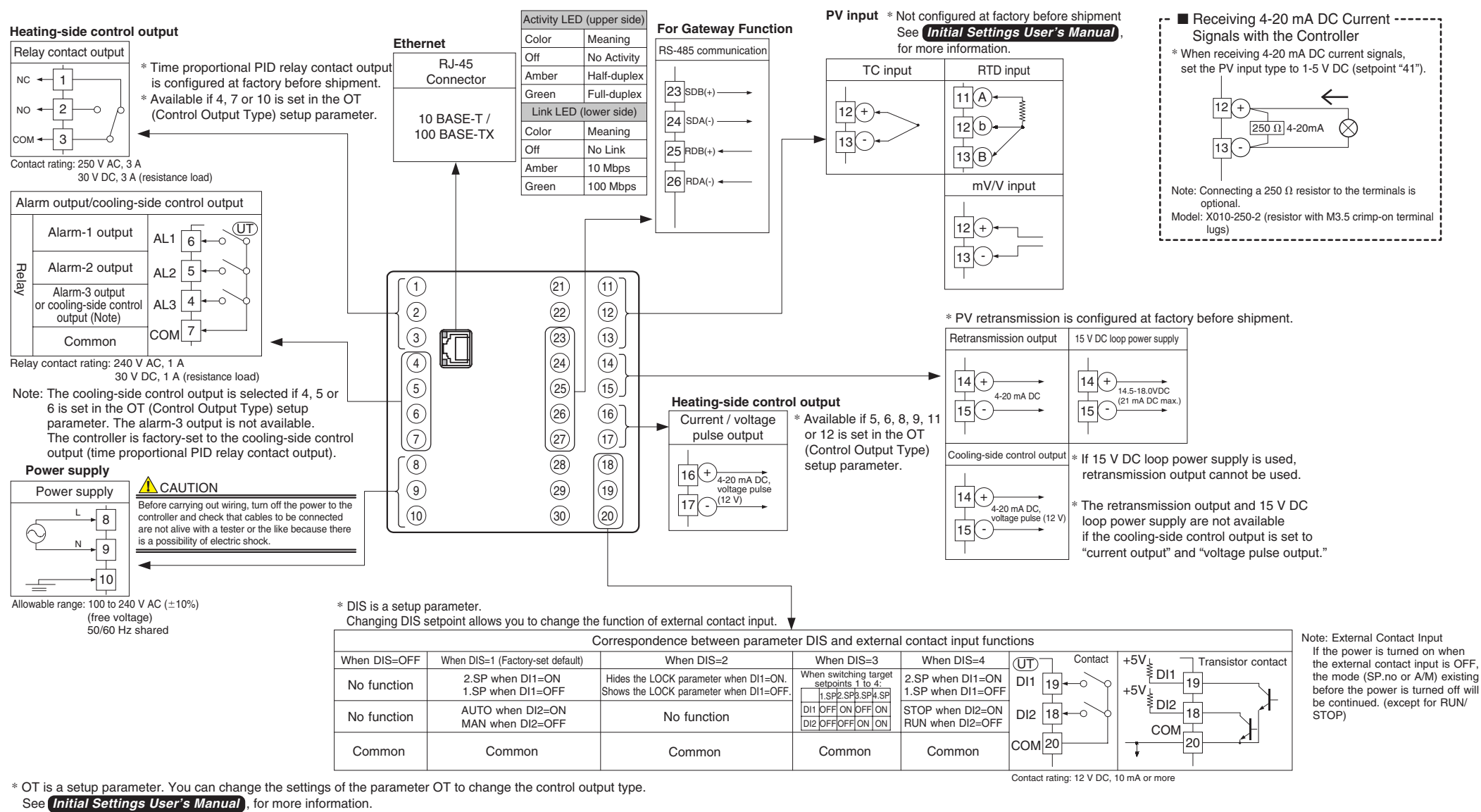

The control output types, "relay output" and "voltage pulse output" shown in the table above refer to those of time proportional control. To change the type to a relay output for on-off control, select "Relay Terminals" and change the setpoint of the proportional band to "0."

This manual describes key entries for operating the controller. For operations using external contact inputs, see "6. Terminal Wiring Diagrams" in **Installation User's Manual**. If you cannot remember how to carry out an operation during setting, press the **[F1]** key for more than 3 seconds. This brings you to the display (operating display) that appears at power-on.

Contents

- Setting Target Setpoint (SP)
- Performing/Canceling Auto-tuning
- Setting PID Manually
- Setting Alarm Setpoints
- Selecting Target Setpoint Numbers (SP.NO)
- Switching between Run and Stop
- Switching between AUTO and MAN
- Manipulating the Control Output in Manual Operation
- Troubleshooting

NOTE

Do not use the instrument generating strong magnetic field such as radio equipment and the like near the controller. This may cause the fluctuation of the PV value.

1. Setting Target Setpoint (SP)

The following operating procedure describes an example of setting 120.0 to a target setpoint. In automatic operation, the controller starts control using set target setpoints.

NOTE

When the target setpoint is set through communication, the target setpoint cannot be changed by keystroke.

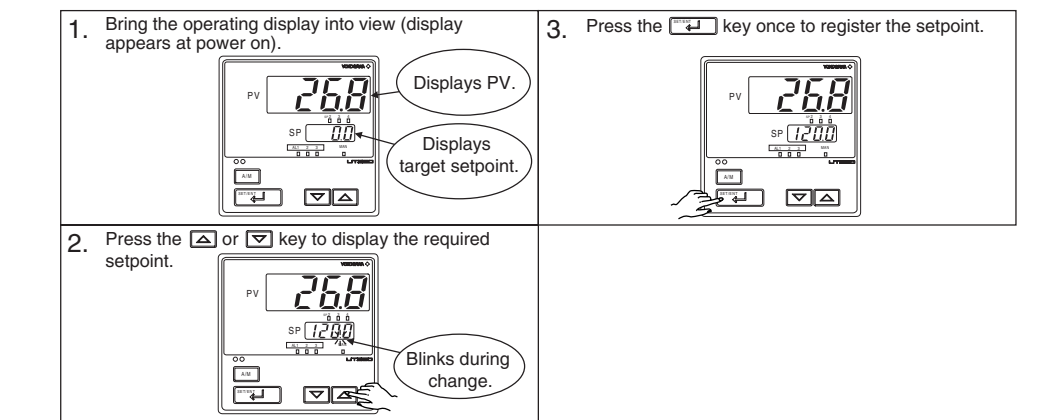

2. Performing/Canceling Auto-tuning

Auto-tuning should be carried out after setting a target setpoint (SP). Make sure the controller is in automatic operation mode (AUTO) and in running state (RUN) before carrying out auto-tuning. See "7. Switching between AUTO and MAN" to change to AUTO and "6. Switching between RUN and STOP" to change to RUN.

NOTE

When on-off control is being used, auto-tuning cannot be carried out. Moreover, do not perform auto-tuning when controlling any of following processes.

- Control processes with quick response such as flow control or pressure control
- Processes where even temporary output on/off results in inconvenience
- Processes where a large output change at control element results in inconvenience
- Processes where variations in PV may exceed an allowable range, adversely affecting product quality

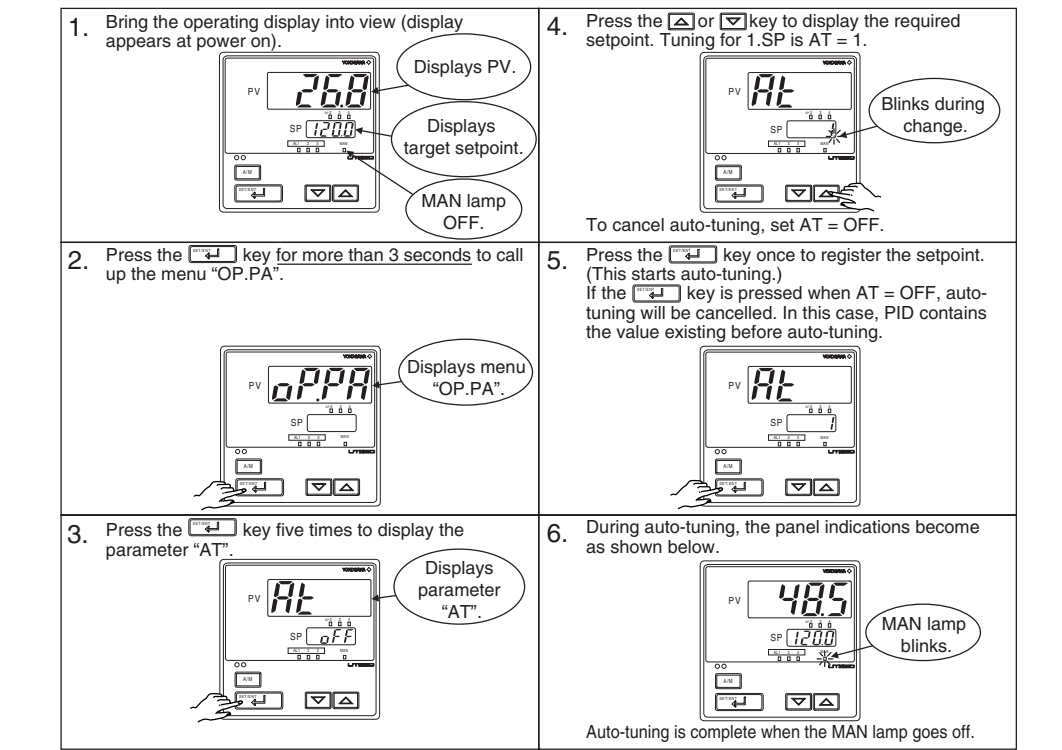

3. Setting PID Manually

If you know the values to be set or if suitable PID constants cannot be obtained by auto-tuning, follow the procedure below to set values.

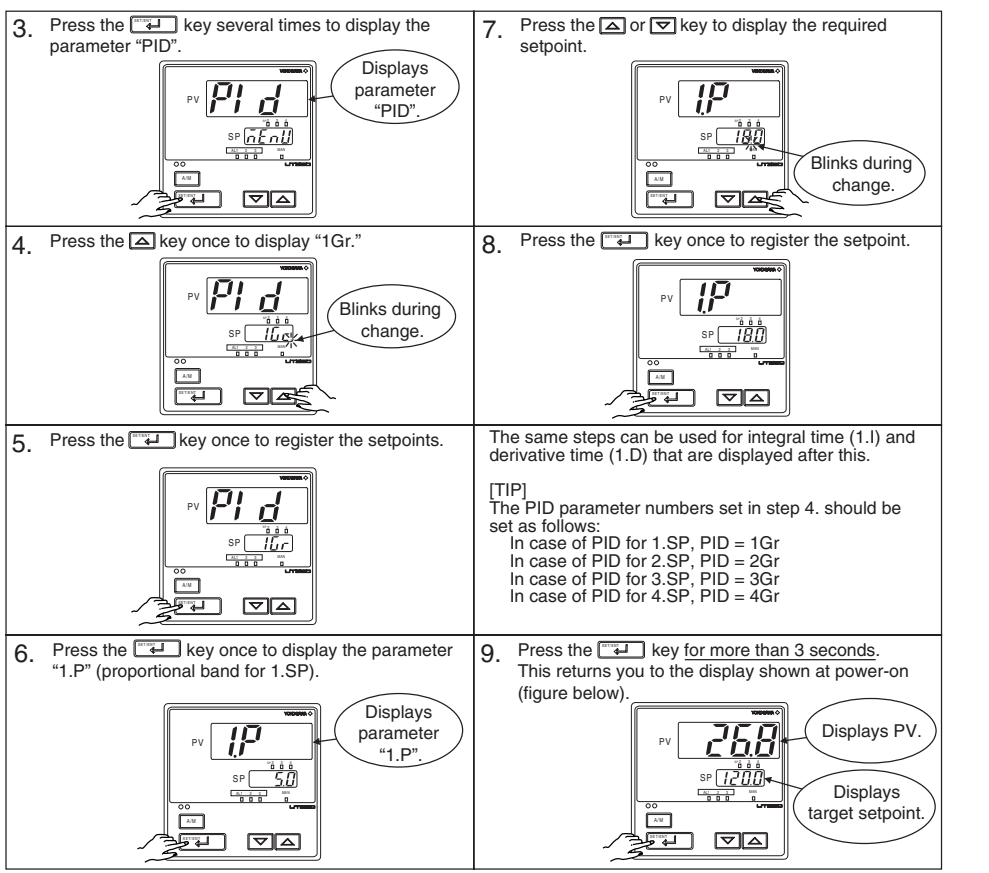
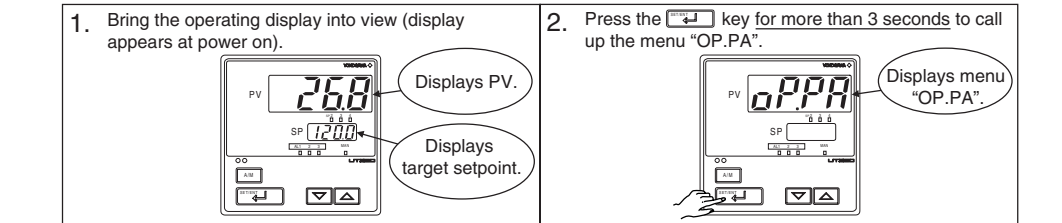

4. Setting Alarm Setpoints

The following operating procedure describes an example of setting 160.0 to alarm-1 setpoint. Check alarm type before setting the alarm setpoint. To change the type of alarm, see "5. Changing Alarm Type" in **Initial Setting User's Manual**.

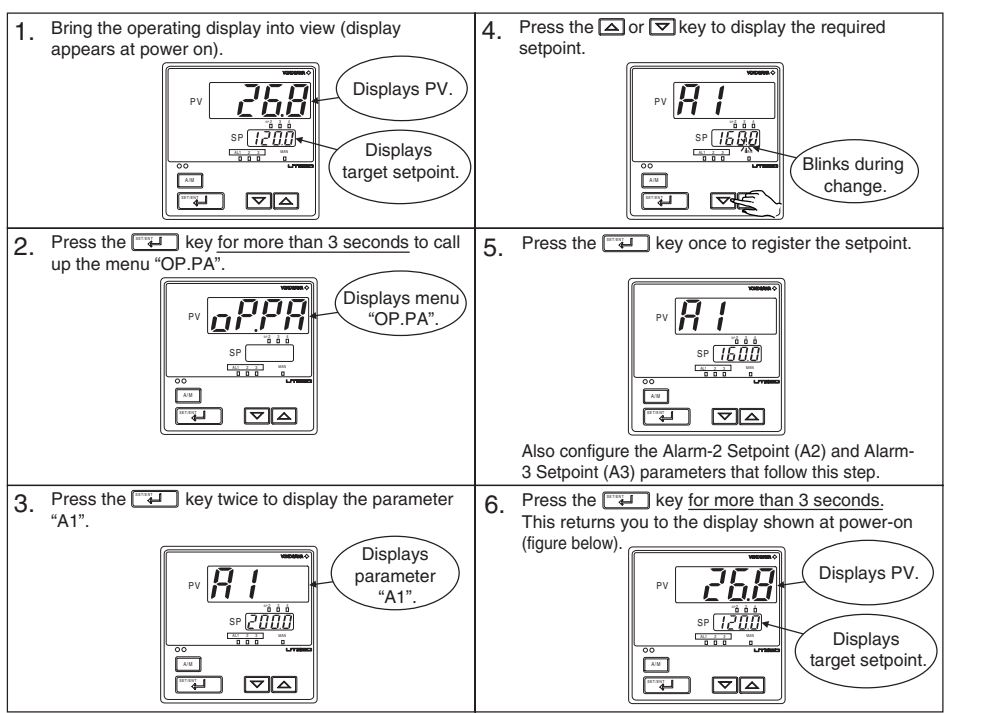

5. Selecting Target Setpoint Numbers (SP.NO)

The following operating procedure describes an example of changing a target setpoint number (SP.NO) from 1 to 2.

NOTE

If a target setpoint number has been switched using contact input, when the contact input is on, that number cannot be selected by keystroke. When using target setpoint ramp setting function, PV tracking works if the target setpoint number is switched.

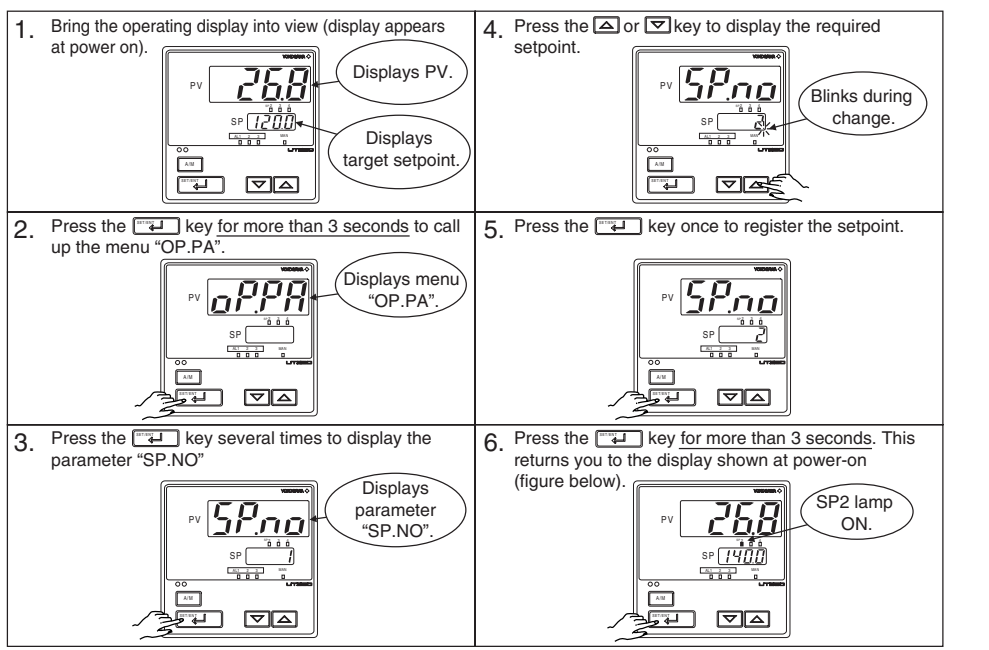

6. Switching between Run and Stop

Switching between the RUN and STOP states can be performed only using external contact input.

NOTE

When the controller is shipped from the factory, it is configured so that switching between the RUN and STOP states cannot be performed. To make the switching possible, configure the DIS setup parameter as "DIS = 4".

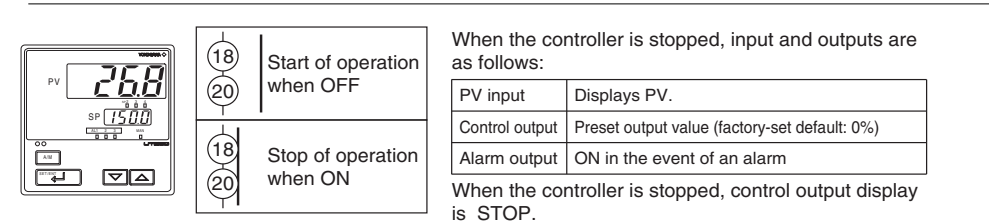

7. Switching between AUTO and MAN

NOTE

If AUTO and MAN have been switched using contact input, when the contact input is ON, switching between AUTO and MAN cannot be achieved by keystroke.

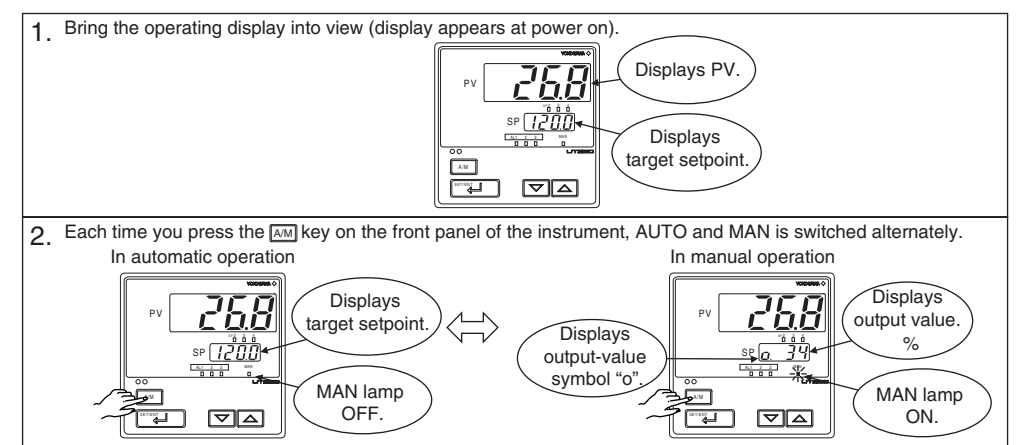

8. Manipulating the Control Output in Manual Operation

NOTE

Control output cannot be changed if the controller is stopped. In this case, the preset output value (setup parameter PO) will be output.

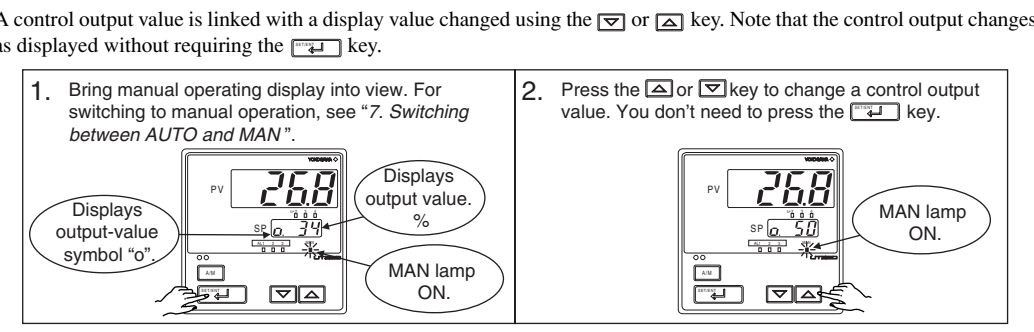

Manipulating the Control Output during Heating/Cooling Control

Either of the following two displays appears when the mode is switched to MAN during heating/cooling control.

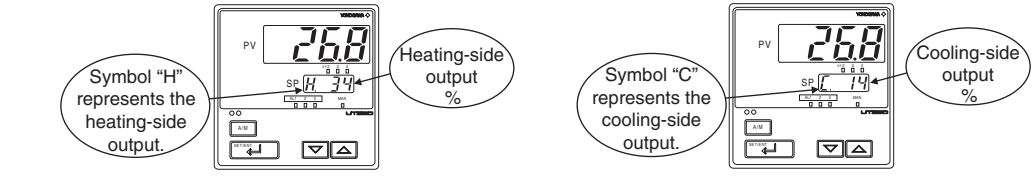

Controller behavior and control output manipulation when the dead band is positive

The following is an example when the DB parameter is set at 12.4%. If you hold down the [F2] key with the heating-side output under manipulation (i.e., cooling-side output C = 0.0%), the heating-side output (H =) decreases. Conversely, both the heating-side and cooling-side outputs change to 0.0%. If you keep the [F2] key held down longer, you enter the state of manipulating the cooling-side output, and its value begins to increase. Inversely, if you hold down the [F2] key with the cooling-side output under manipulation (i.e., heating-side output H = 0.0%), the cooling-side output (C =) decreases. Consequently, both the heating-side and cooling-side outputs go to 0.0%. If you keep the [F2] key held down longer, you enter the state of manipulating the heating-side output, and its value begins to increase.

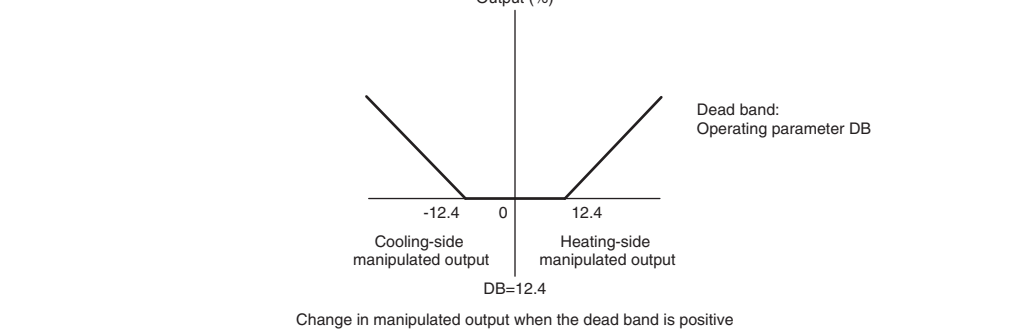

9. Troubleshooting

Troubleshooting Flow

If the operating display does not appear after turning on the controller's power, follow the measures in the procedure below. If an problem appears complicated, contact our sales representative.

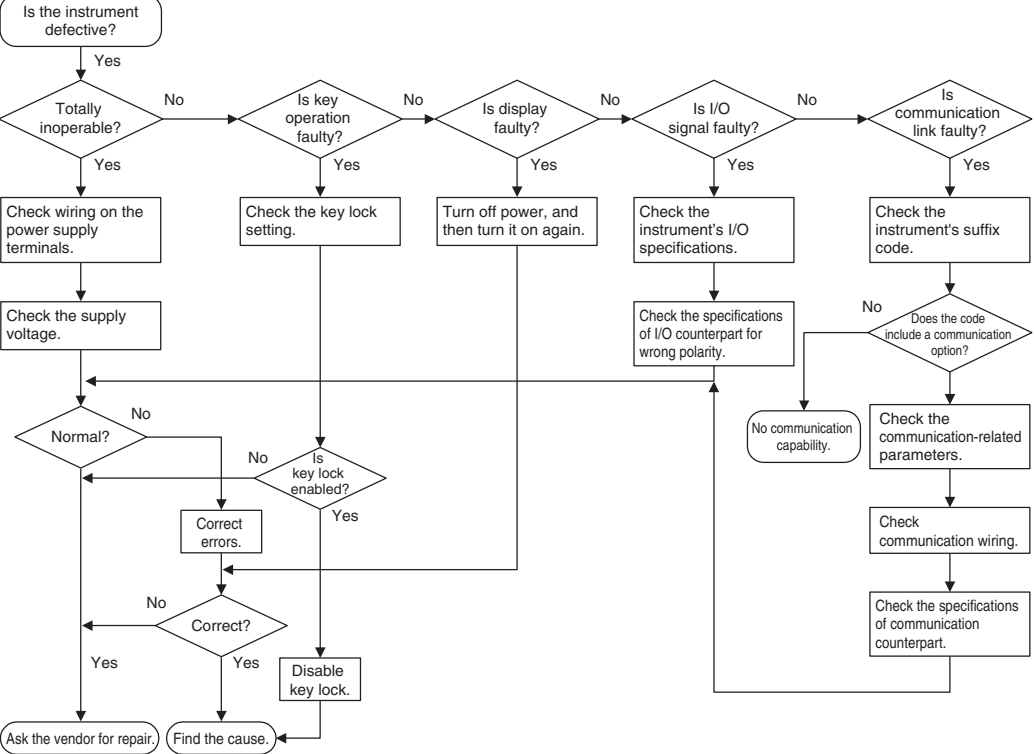

IMPORTANT

Take note of the parameter settings when asking the vendor for repair.

Errors at Power On

The following table shows errors that may be detected by the fault diagnosis function when the power is turned on.

Error indication (on PV display unit)	Description of error	PV	Control output	Alarm output	Retransmission output	Communication	Remedy
E000 (E000)	Faulty RAM	None	0% or less or OFF	OFF	0% or less	Stopped	Faulty Contact us for repair.
E001 (E001)	Faulty ROM	None	0% or less or OFF	OFF	0% or less	Stopped	
E002 (E002)	System data error	0%	0% or OFF	OFF	0%	Stopped	
PV decimal point blinks.	Faulty calibration value	Normal action (out of accuracy)	Normal action (out of accuracy)	Normal action (out of accuracy)	Normal action (out of accuracy)	Normal action	Check and set the parameters, as they have been set to the limited values.
E400 (E400)	Parameter error	0%	Preset value output	OFF	0%	0%	Check and set the parameters, as they have been set to the limited values.

Possible Errors during Operation

The following shows possible errors occurring during operations.

Error indication (on PV display unit)	Description of error	PV	Control output	Alarm output	Retransmission output	Communication	Remedy
Displays "RJC" and PV alternately	RJC error	Measured with RJC=OFF	Normal action	Normal action	Normal action	Normal action	Faulty Contact us for repair.
PV value blinks.	EEPROM error	Normal action	Normal action	Normal action	Normal action	Normal action	Faulty Contact us for repair.
E300 (E300)	A/DC error	105%	Preset value output	Normal action	Normal action	Normal action	Check wires and sensor.
boUt (B.OUT)	PV burnout error	Dependent on the BSL parameter Up-scale: 105% Down-scale: -5%	Preset value output	Normal action	Normal action	Normal action	Check wiring and sensor.
oBr (OVER) or -oBr (-OVER)	Excessive PV Out of -5 to 105%	-5% or 105%	Normal action	Normal action	Normal action	Normal action	Check process.
E200 (E200)	Auto-tuning failure (Time-out)	Normal action	Normal action	Normal action	Normal action	Normal action	Check process. Press any key to erase error indication.
SP decimal point blinks. (on setpoint display unit)	Faulty communication	Normal action	Normal action	Normal action	Normal action	Stopped	Check the Ethernet communication parameters if the error occurs continuously. When the settings are correct, it is faulty. Contact us for repair. Check the error of RS-485 side by the connected controller.
All indications off	Runaway (due to defective power or noise)	None	0% or less or OFF	OFF	0% or less	Stopped	Faulty if power off/on does not reset start the unit. Contact us for repair.
All indications off	Power off	None	0%	OFF	0%	Stopped	Check for abnormal power.

If a Power Failure Occurs during Operation

● Momentary power failures shorter than 20 ms
The controller is not affected at all and continues normal operation.

● Power failures of 20 ms or longer

- The alarm function of the controller continues to work normally. (Alarms with the stand-by feature temporarily return to their stand-by state, however.)
- Setting parameters that have already been configured retain their settings.
- Auto-tuning is cancelled.
- After recovery from a power failure, control action resumes in the same mode as the one before the occurrence of the power failure. The control output begins with the preset output value.

Troubleshooting When the Controller Fails to Operate Correctly

If your control tasks are not successful, check the preset parameters and controller wiring before concluding the controller to be defective. The following show some examples of troubleshooting you should refer to in order to avoid the possibility of other problems.

● The controller does not show the correct measured input (PV).

- The UT351-xA controllers has a universal input. The type of PV input can be set/changed using the parameter "IN". At this point, the controller must be wired correctly according to the selected type of PV input. Check the wiring first if the controller fails to show the correct PV. To do this, refer to **Initial Settings User's Manual**. With the parameters "RH", "RL", "SDP", "SH" and "SL", it is possible to scale the input signal and change its number of decimal places. Also check that these parameters are configured correctly.

● The controller does not provide any control output or the control output does not change at all.

- The UT351-xA controllers has a universal output. The type of control output can be set/changed using the parameter "OT". At this point, the controller must be wired correctly according to the selected type of control output. Check the wiring first if the controller provides no control output. To do this, refer to "6. Terminal Wiring Diagrams" in **Installation User's Manual**. With the parameters "OH" and "OL", it is possible to set/change the high and low limits of control output. The control output may not change at all, however, because of restrictions on these parameters. Also check the restrictions on these parameters.

● The control output can only be changed when the controller is in the MAN mode.
If the MAN lamp is off (i.e., the controller is in the AUTO mode), you cannot change the control output using key operation.

● The control output does not change soon after the target setpoint SP has been changed.

- If this happens, check the setting of the parameter "C.MD". In cases where fixed-point control is selected as the PID control mode (C.MD = 1), tracking based on the I-term works to prevent the control output from changing suddenly even if the target setpoint SP is varied. The control output therefore may appear to be working incorrectly at first; however it gradually adapts itself to the new target setpoint.

2. Lists of Parameters

* Parameters relating to PV or setpoints should all be set in real numbers. For example, use temperature values to define target setpoints and alarm setpoints for temperature input.

Operating Parameters

Parameter Symbol	Name of Parameter	Setting Range and Description	Initial Value	User Setting
LL (LL)	LL communication interface selection	OFF: Communication is carried out via the Ethernet communication terminals. ON: Communication is carried out via the light-loader adapter.	OFF	
A1 (A1)	Alarm 1-setpoint	PV alarm / SP alarm: -100.0 to 100.0% of PV input range Deviations alarm: -100.0 to 100.0% of PV input range span Output alarm: -5.0 to 105.0%. An alarm common to the 1.SP to 4.SP parameters.	PV high limit/SP high limit alarm: 100.0% of PV input range Deviations alarm: 0.0% of PV input range span Other PV/SP low limit alarm: 0.0% of PV input range Output high limit alarm: 100.0% Output low limit alarm: 0.0%	
A2 (A2)	Alarm 2-setpoint			
A3 (A3)	Alarm 3-setpoint			
At (AT)	Auto-tuning	OFF: No auto-tuning 1: Auto-tuning for 1.SP 2: Auto-tuning for 2.SP 3: Auto-tuning for 3.SP 4: Auto-tuning for 4.SP AUTO: Performs auto-tuning to all groups 1 to 4.	OFF	
SC (SC)	"Super" function	OFF: Disable 1: Overshoot suppressing function Suppresses overshoots generated by abrupt changes in the target setpoint or by disturbances. 2: Hunting suppressing function (Stable mode) Suitable to stabilize the state of control when the load varies greatly, or the target setpoint is changed. Enables to answer the wider characteristic changes compared with Response mode. 3: Hunting suppressing function (Response mode) Enables quick follow-up and short converging time of PV for the changed target setpoint. Note: Use "SUPER" function (SC) 2 or 3 in PID control or PI control. "SUPER" function 2 or 3 is not available in the following control: 1) ON/OFF control 2) P control (control for proportional band only) 3) PD control (control for proportional band and derivative item only) 4) Heating/cooling control Do not use hunting suppressing function when control processes with response such as flow or pressure control.	OFF	
SPno (SPNO)	Target setpoint number selection	0: Uses target setpoint via communication 1: Selects target setpoint 1 (1.SP) 2: Selects target setpoint 2 (2.SP) 3: Selects target setpoint 3 (3.SP) 4: Selects target setpoint 4 (4.SP)	1	
PI d (PID)	PID parameter display number	MENU: Move to FL parameter display menu 10 to 4Gr: Display of each PID parameter	MENU	
FL (FL)	PV input filter	OFF, 1 to 120 second. Used when the PV input fluctuates.	OFF	
bs (BS)	PV input bias	-100.0% to 100.0% of PV input range span Used to correct the PV input range.	0.0% of PV input range span	
UPr (UPR)	Setpoint ramp-up-rate	OFF 0.0% + 1 digit of PV input range span to 100.0% of PV input range span Set ramp-up-rate or ramp-down-rate per hour or minute.	OFF	
dnr (DNR)	Setpoint ramp-down-rate	OFF Sets unit in ramp-rate-time unit (TMU).	OFF	
oH (OH)	Output high limit (in heating/cooling control)	-5.0 to 105.0% Heating-side limiter in heating/cooling control: 0.0 to 105.0% (OL < OH)	100% Heating/cooling control: 100.0%	
oL (OL)	Output low limit (in heating/cooling control)	-5.0 to 105.0% Cooling-side limiter in heating/cooling control: 0.0 to 105.0% (OL < OH)	0.0% Heating/cooling control: 100.0%	
H (H)	ON/OFF control hysteresis (in heating/cooling control)	In ON/OFF control: 0.0 to 100.0% of PV input range span In heating/cooling control: 0.0 to 10.0%	ON/OFF control: 0.5% of PV input range span Heating/cooling control: 0.5%	
dr (DR)	Direct/reverse action switching	0: reverse action, 1: direct action Control output	0	
PCCH (PCCH)	High limit for PV color change	When PCMD (PV color mode parameter) = 6 or 7: -100.0 to 100.0 % of PV input range When PCMD (PV color mode parameter) = 8 or 9: -100.0 to 100.0 % of PV input range span	When PCMD = 6 or 7: PCCH = 100.0% PCCL = 0.0 % When PCMD = 8 or 9: PCCH and PCCL = 1.0 %	
PCCL (PCCL)	Low limit for PV color change			
orb (ORB)	ON/OFF rate detection band	0.0 to 100.0% of PV input range span	1.0% of PV input range span	
orH (ORH)	ON/OFF rate high limit	ORL + 1 digit to 105.0%	100.0%	
orL (ORL)	ON/OFF rate low limit	-5.0% to ORH - 1 digit	0.0%	
or (OR)	ON/OFF rate	This is not a setpoint.	The moving average (for 5 cycle times) of the control output is shown.	
1SP (1.SP)	Target setpoint-1	0.0 to 100.0% of PV input range However, between target setpoint limiter lower limit (SPL) and upper limit (SPH).	0.0% of PV input range	
2SP (2.SP)	Target setpoint-2			
3SP (3.SP)	Target setpoint-3			
4SP (4.SP)	Target setpoint-4			

Note: The parameters HB1, HB2, HC1 and HC2 are displayed between DR and ORB or PCCL and ORB. But these parameters do not affect the functions and operations even if they are set up.

PID-related Parameters

The following parameters are displayed when "IGr" is set to PID parameter display number (PID). In this case, the corresponding target setpoint is 1.SP (target setpoint-1).
To set PID corresponding to target setpoint 2 to 4, set "2Gr", "3Gr", or "4Gr" to PID. The relevant parameters will then be displayed.

Parameter Symbol	Name of Parameter	Setting Range and Description	Initial Value	User Setting
IP (1.P)	Proportional band/Heating-side proportional band (in heating/cooling control)	0.1 to 999.9% In heating/cooling control: 0.0 to 999.9% (heating-side ON/OFF control applies when 0.0)	5.0%	
I (1.I)	Integral time/Heating-side integral time (in heating/cooling control)	OFF, 1 to 6000 second	240 second	
Id (1.D)	Derivative time/Heating-side derivative time (in heating/cooling control)	OFF, 1 to 6000 second	60 second	
inr (1.MR)	Manual reset (enabled when integral time "I" is OFF) The manual reset value equals the output value when PV = SP is true. For example, if the manual reset value is 50%, the output value is 50% when PV = SP becomes true.	-5.0 to 105.0%	50.0%	
IPc (1.Pc)	Cooling-side proportional band	0.0 to 999.9% (Cooling-side ON/OFF control applies when 0.0)	5.0%	
Ic (1.Ic)	Cooling-side integral time	OFF, 1 to 6000 second	240 second	

* The "User Setting" column in the table below is provided for the customer to record setpoints.

Parameter Symbol	Name of Parameter	Setting Range and Description	Initial Value	User Setting
Idc (1.Dc)	Cooling-side derivative time	OFF, 1 to 6000 second	60 second	
Idb (1.Db)	Deadband	-100.0 to 50.0% In heating/cooling control, a region where both of the heating- and cooling-side outputs are presented, or none of them is presented, can be set.	3.0%	
lrP (1.RP)	Zone PID reference point-1	0.0 to 100.0% of PV input range. Note that 1.RP ≤ 2.RP.	100% value of PV input range	

Refer to the table below for recording setpoints when two sets or more of PID parameters are used.

Parameter	n=2	n=3	n=4
n.P			
n.I			
n.D			
n.MR			
n.Pc			
n.Ic			
n.Dc			
n.Db			
n.RP		None	None

Parameter Symbol	Name of Parameter	Setting Range and Description	Initial Value	User Setting
rdb (RDV)	Reference deviation	OFF, 0.0 to 100.0% of PV input range span Used to select PID constants according to a deviation from the setpoint. The 4th group of PID constants is used when the controller fails to keep track of the deviation.	OFF	

Auto-tuning

Auto-tuning is a function with which the controller automatically measures the process characteristics to automatically set the optimum PID constants. This function does not work when the controller is performing on-off control. The UT351-xA employ the "Limit Cycle Method." As shown in the figure on the right, the controller temporarily changes its control output in a step-waveform manner. Then, it calculates the optimum proportional band (P), integral time (I) and derivative time (D) from the resulting response to set them in their respective parameters. If the Output High Limit (OH) and Output Low Limit (OL) parameters are already configured, the control output turns on and off only between the output's high and low limits during auto-tuning.

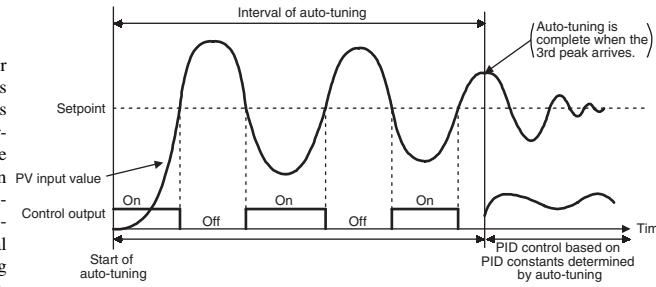

Auto-tuning Using Zone PID (see "PID Switching (Zone PID)" later in this manual)

Setting of AT Parameter	Auto-tuned Setpoint	Remarks
OFF	-	Auto-tuning is turned off (disabled).
1	The setpoints when auto-tuning is started	Determines the values of 1.P, 1.I and 1.D parameters by auto-tuning.
2		Determines the values of 2.P, 2.I and 2.D parameters by auto-tuning.
3		Determines the values of 3.P, 3.I and 3.D parameters by auto-tuning.
4		Determines the values of 4.P, 4.I and 4.D parameters by auto-tuning.
AUTO	Median value of each zone width	Determines the values of all PID parameters in use by auto-tuning.

The AT parameter settings numbered 1 to 4 in the table above are dependent on how many zones have been set. For example, if you have set two zones, you can use AT parameter settings 1 and 2. Likewise, if you have set three zones, you can use AT parameter settings 1, 2 and 3.

Hysteresis (for Target Setpoints (On-Off Control) and Alarm Setpoints)

Hysteresis can be set in on-off control setpoints and alarm setpoints as well. With the hysteresis settings, it is possible to prevent relays from chattering.

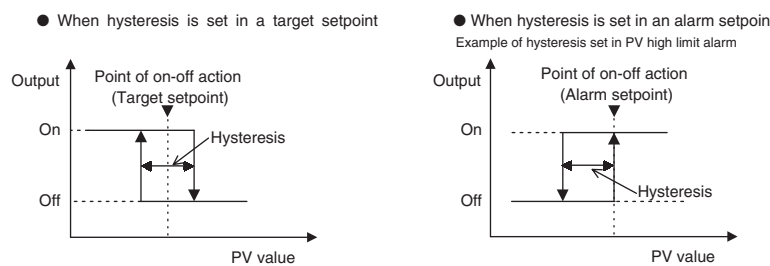

Target Setpoint Ramp Setting Function

Use this function to prevent the target setpoint from changing suddenly. The ramp setting function works when:

- the target setpoint is changed (example: change in "1.SP" from 100°C to 150°C);
- the target setpoint number is switched (example: switch from "1.SP" to "3.SP");
- the power is turned on or the controller is recovered from power failure;
- a change is made from manual operation to automatic operation; or
- a change is made from the STOP state to the RUN state.

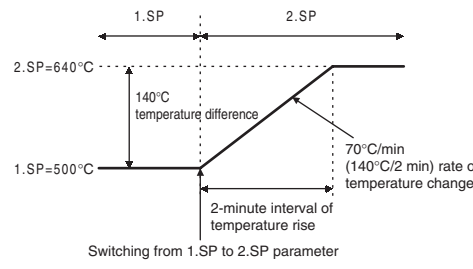

PID Switching (Zone PID)

Using a zone PID, you can automatically switch between groups of PID constants according to the temperature zone. You can set a maximum of three temperature zones.

- Setting Method:
- Set the Zone PID Selection (ZON) parameter to "ON".
 - Define a reference point. When using two zones, define only reference point 1 (1.RP) between the minimum and maximum values of the PV input range. When using three zones, define reference points 1 and 2 (1.RP and 2.RP) in the same way as noted above.

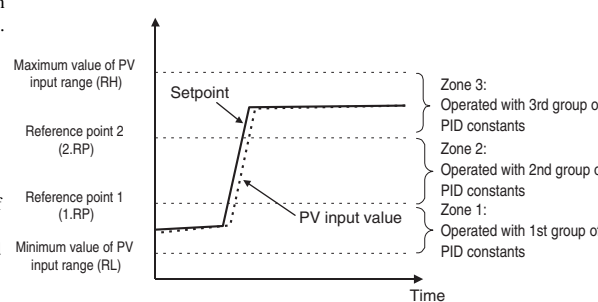

Note: Set the maximum and minimum values, as close as possible to those of the actual range to be controlled, in the Maximum Value of PV Input Range (RH) and Minimum Value of PV Input Range (RL) parameters. Otherwise, the controller may fail to determine the optimum values when auto-tuning is carried out.

Setup Parameters

Control Function-related Parameters

Parameter Symbol	Name of Parameter	Setting Range and Description	Initial Value	User Setting
SPH (SPH)	Target setpoint limiter upper limit	0.0 to 100.0% of PV input range where, SPL < SPH Places a limit on the range within which the target setpoint is changed.	100.0% of PV input range	
SPL (SPL)	Target setpoint limiter lower limit		0.0% of PV input range	
PCMD (PCMD)	PV color mode	0: Fixed in green 1: Fixed in red 2: Link to alarm 1 (Alarm OFF:green, Alarm ON:red) 3: Link to alarm 1 (Alarm OFF:red, Alarm ON:green) 4: Link to alarm 1 and 2 (Alarm OFF:green, Alarm ON:red) 5: Link to alarm 1 and 2 (Alarm ON:red, Alarm OFF:green) 6: PV limit (Within PV range:green, Out of PV range:red) 7: PV limit (Within PV range:red, Out of PV range:green) 8: SP deviation (Within deviation:green, Out of deviation:red) 9: SP deviation (Within deviation:red, Out of deviation:green)	1	
AL1 (AL1)	Alarm-1 type	OFF, 1 to 23, 28 to 31, 33 to 38, 43 to 48 1: PV high limit (energized, no stand-by action) 2: PV low limit (energized, no stand-by action) 3: Deviation high limit (energized, no stand-by action) 4: Deviation low limit (energized, no stand-by action) 5: Deviation high limit (de-energized, no stand-by action) 6: Deviation low limit (de-energized, no stand-by action) These Alarm Type parameters are common to the parameters 1.SP to 4.SP. See "List of Alarm Types" on the back for other alarm types.	1	
AL2 (AL2)	Alarm-2 type		2	
AL3 (AL3)	Alarm-3 type		1	
HY1 (HY1)	Alarm-1 hysteresis	0.0 to 100.0% of PV input range span Output alarm: 0.0 to 100.0%	0.5% of PV input range span Output alarm: 0.5%	
HY2 (HY2)	Alarm-2 hysteresis			
HY3 (HY3)	Alarm-3 hysteresis			
dy1 (DY1)	Alarm-1 delay timer	An alarm is output when the delay timer expires after the alarm setpoint is reached. 0.00 to 99.99 (min. sec.) (enabled when alarm-1 type "AL1" is 1 to 20 or 28 to 31)	0.00	
dy2 (DY2)	Alarm-2 delay timer	0.00 to 99.99 (min. sec.) (enabled when alarm-2 type "AL2" is 1 to 20 or 28 to 31)		
dy3 (DY3)	Alarm-3 delay timer	0.00 to 99.99 (min. sec.) (enabled when alarm-3 type "AL3" is 1 to 20 or 28 to 31)		
ct (CT)	Control output cycle time	1 to 1000 second	30 second	
ctc (CTC)	Cooling-side control output cycle time	1 to 1000 second	30 second	
PO (PO)	Preset output/Heating-side preset output (in heating/cooling control)	-5.0 to 105.0% In heating/cooling control: Heating side 0.0 to 105.0% In Stop mode, fixed control output can be generated.	0.0%	
Poc (Poc)	Cooling-side preset output	0.0 to 105.0% In Stop mode, cooling-side fixed control output can be generated.	0.0%	
CMD (C.MD)	PID control mode	0: Standard PID control (with output bump at SP change) 1: Fixed point control (without output bump at SP change) Choose "fixed point control" when controlling pressure or flow rate.	0	
ZON (ZON)	Zone PID selection	OFF: SP selection ON: Zone PID	OFF	
AR (AR)	Anti-reset windup (Excess integration prevention)	AUTO (0), 50.0 to 200.0% Used when the control output travels up to 100% or down to 0% and stays at this point. The larger SP, the sooner PID computation (integral computation) stops.	AUTO	
tmu (TMU)	Ramp-rate time unit setting	0: hour, 1: minute Time unit of setpoint ramp-up (UPR) and setpoint ramp-down (DNR)	0	
HSR (HSR)	High-speed response mode	OFF: The process data high-speed response function is not used. 1: The process data of the device itself is returned as a response at high speed. 2 to 6: The process data of the device itself and the process data from the serial communication devices connected to the RS485 communication terminals are returned as a response at high speed. The maximum address of the serial devices is specified. Note: Set the continuous communication address which begins from "2" for other serial communication devices connected to the RS485 communication terminals. Note: After setting the parameter DLM, set the Ethernet setting switch ESW to "1" to activate the settings. If other parameters (Parity, IP address, subnet mask or default gateway) are also changed, activate the settings at the end.	1	
Pr1 (Pr1)	Parity	Set the parity of RS485 communication to be connected to the Ethernet-serial gateway function. NONE: None, EVEN: Even, ODD: Odd Note: Set the same parity as that of the other devices to be connected. Note: After setting the parameters Pr1, set "1" for the parameter ESW to make the setting effective.	EVEN	
IP1 (IP1)	IP address 1	Set the IP address by the following format.	192	
IP2 (IP2)	IP address 2		168	
IP3 (IP3)	IP address 3	IP address: IP1, IP2, IP3, IP4	1	
IP4 (IP4)	IP address 4	Note: After setting the parameters IP, set "1" for the parameter ESW to make the setting effective.	1	
SM1 (SM1)	Subnet mask 1	Set the Subnet Mask by the following format.	255	
SM2 (SM2)	Subnet mask 2		255	
SM3 (SM3)	Subnet mask 3	Subnet Mask: SM1, SM2, SM3, SM4	255	
SM4 (SM4)	Subnet mask 4	Note: After setting the parameters SM, set "1" for the parameter ESW to make the setting effective.	0	
DG1 (DG1)	Default gateway 1	Set the Default gateway by the following format.	0	
DG2 (DG2)	Default gateway 2		0	
DG3 (DG3)	Default gateway 3	Default gateway: DG1, DG2, DG3, DG4	0	
DG4 (DG4)	Default gateway 4		0	
Pr1 (Pr1)	Port Number	Set the HEX data format. Setting range: 01F6 (502), 0400 (1024) to FFFF (65535) Note: After setting the parameters Pr1, set "1" for the parameter ESW to make the setting effective.	01F6h (502)	
ESW (ESW)	Ethernet setting switch	Make sure to set "1" for the parameter ESW after setting the parameters HSR through Pr1. The setting of the parameters HSR through DGM become effective by setting "1" for the parameter ESW. (The setting also become effective by power OFF/ON.) Note: The parameter ESW automatically returns to "0" after "1" is set.	0	
TEST (TEST)	Test parameter	If this parameter symbol appears, press the SET/ENT key to return to the FUNC menu. Caution: Do not change the setpoint of the TEST parameter, otherwise the controller will be disabled.		

Input-/Output-related Parameters

Parameter Symbol	Name of Parameter	Setting Range and Description	Initial Value	User Setting
IN (IN)	PV input type (PV INPUT terminals)	OFF, 1 to 18, 30, 31, 35 to 37, 40, 41, 50, 51, 55, 56 See Instrument Input Range Codes in "Initial Settings" User's Manual.	OFF	
Unit (UNIT)	PV input unit	°C-degree Celsius °F: Fahrenheit (This parameter is not shown for voltage input.)	°C	
RH (RH)	Max. value of PV input range	Set the PV input range, however RL < RH Temperature input Set the range of temperature that is actually controlled.	Max. value of instrument input range	
RL (RL)	Min. value of PV input range	- Voltage input Set the range of a voltage signal that is applied. The scale across which the voltage signal is actually controlled should be set using the parameters Maximum Value of PV Input Scale (SH) and Minimum Value of PV Input Scale (SL).	Min. value of instrument input range	
SDP (SDP)	PV input decimal point position (displayed at voltage input)	0 to 3 Set the position of the decimal point of voltage-mode PV input. 0: No decimal place 1: One decimal place 2, 3: Two, three decimal places	1	
SH (SH)	Max. value of PV input scale (displayed at voltage input)	-1999 to 9999, however SL < SH Set the read-out scale of voltage-mode PV input.	100.0	
SL (SL)	Min. value of PV input scale (displayed at voltage input)		0.0	
rJc (RJC)	Presence/absence of PV input reference junction compensation	OFF, ON	ON	
ErJc (ErJc)	External RJC setpoint	-50.0 to 50.0 °C -56.0 to 122.0 °F For thermocouple input, temperature compensation value outside the controller can be set. Available only when RJC=OFF.	0.0 °C 32.0 °F	
bSL (BSS)	Selection of PV input burnout action	OFF 1: Up scale 2: Down scale	1	
ot (OT)	Control output type	0: Time proportional PID relay contact output (terminals ①-②-③) 1: Time proportional PID voltage pulse output (terminals ④-⑦) 2: Current output (terminals ⑧-⑩) 3: ON/OFF control relay contact output (terminals ①-②-③) The following 4 to 12 are displayed only for heating/cooling type controllers. 4: Heating-side relay output (terminals ①-②-③), cooling-side relay output (terminals ④-⑦) 5: Heating-side pulse output (terminals ⑧-⑩), cooling-side pulse output (terminals ④-⑦) 6: Heating-side current output (terminals ⑧-⑩), cooling-side current output (terminals ④-⑦) 7: Heating-side relay output (terminals ①-②-③), cooling-side pulse output (terminals ⑧-⑩) 8: Heating-side pulse output (terminals ⑧-⑩), cooling-side pulse output (terminals ⑧-⑩) 9: Heating-side current output (terminals ⑧-⑩), cooling-side pulse output (terminals ⑧-⑩) 10: Heating-side relay output (terminals ①-②-③), cooling-side current output (terminals ⑧-⑩) 11: Heating-side pulse output (terminals ⑧-⑩), cooling-side current output (terminals ⑧-⑩) 12: Heating-side current output (terminals ⑧-⑩), cooling-side current output (terminals ⑧-⑩)	0	Heating/cooling type: 4
rEt (REt)	Retransmission output type	1: PV, 2: SP, 3: OUT, 4: Loop power supply for sensor (15 V) In heating/cooling control, an output value before allocation to heating and cooling control (0 to 100%) is transmitted if setpoint "P" is selected (0 to 50%; Cooling-side output; 50 to 100%; Heating-side output).	1	
rth (RTH)	Max. value of retransmission output scale	RET=1, 2: RTH + 1 digit to 100.0% of PV input range	100.0% of PV input range	
rL (RL)	Min. value of retransmission output scale	RET=1, 2: 0.0% of PV input range to RTH - 1 digit	0.0% of PV input range	
DIS (DIS)	DI function selection	OFF: Disables the external contact input. 1: DI1: 2.SP (on)/1.SP (off), DI2: AUTO (on)/MAN (off) DI2: Unused. 3: See the table below. 4: DI1: 2.SP (on)/1.SP (off), DI2: STOP (on)/RUN (off)	1	

○ SP Selection when DIS = 3 is set

	DI1	DI2
1.SP	OFF	OFF
2.SP	ON	OFF
3.SP	OFF	ON
4.SP	ON	ON

C51 (C51)	SELECT display-1 registration	OFF, 201 to 1015 Select the desired parameter from among the operating and setup parameters, then register the number (D register No.) accompanying that parameter. For example, registering "231" for C51 allows you to change alarm-1 setpoint in operating display.	OFF	
C52 (C52)	SELECT display-2 registration			
C53 (C53)	SELECT display-3 registration	Numbers for registering alarm SP parameter for operating display: Alarm 1 setpoint: 231 Alarm 3 setpoint: 233 Above numbers are alarm setpoint parameters for target setpoint-1 (1.SP).		
C54 (C54)	SELECT display-4 registration			
LoCK (LoCK)	Key lock	OFF: No key lock 1: Change to any parameter prohibited Prohibits any operating parameter or setup parameter from being changed. The setpoint of the LOCK parameter itself can be changed, however. 2: Change to and display of operating parameters prohibited Turns off the display for setting operating parameters, thus prohibiting any change to the parameter settings. (Hold down the SET/ENT key for more than 3 seconds to show the password check display.) 3: Disables the AM key on the instrument's front panel.	OFF	
PwD (PwD)	Password setting	0: Password not set 1 to 9999	0	











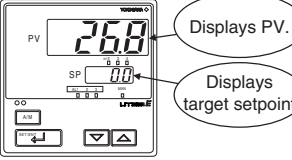

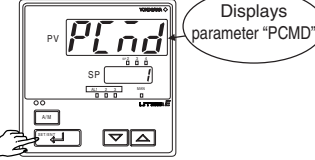

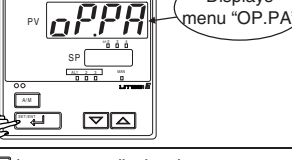

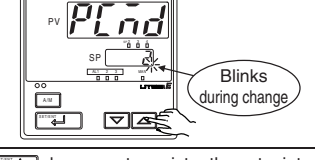
This manual describes the PV display color changing function "Active Color PV Display."

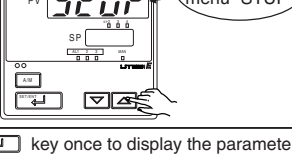
Carry out settings according to the following procedures after referring to "Functions of Active Color PV Display" on the back of this manual. Use "Parameter Map" of Parameters User's Manual to understand the required parameters. If you cannot remember how to carry out an operation during setting, press the  key for more than 3 seconds. This brings you to the display (operating display) that appears at power-on.

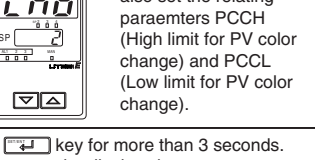
■ Setting the PV Display Color Changing Function "Active Color PV Display"

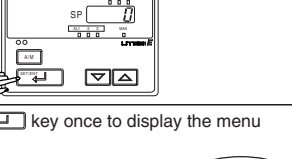
The following operating procedure describes an example of changing the PV color mode (factory-set default: Fixed in red mode) to Link to alarm 1 mode.

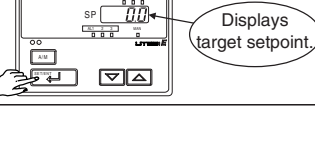

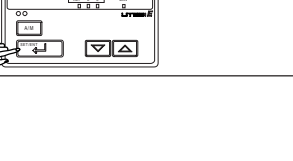





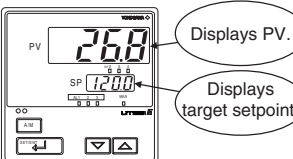

Parameter Symbol	Name of Parameter	Setting Range	Initial Value
PCMD (PCMD)	PV color mode	0 : Fixed in green 1 : Fixed in red 2 : Link to alarm 1 (Alarm OFF:green, Alarm ON: red) 3 : Link to alarm 1 (Alarm OFF:red, Alarm ON:green) 4 : Link to alarm 1 and 2 (Alarm OFF:green, Alarm ON:red) 5 : Link to alarm 1 and 2 (Alarm OFF:red, Alarm ON:green) 6 : PV limit (Within PV range:green, Out of range:red) 7 : PV limit (Within PV range:red, Out of range:green) 8 : SP deviation (Within deviation:green, Out of deviation:red) 9 : SP deviation (Within deviation:red, Out of deviation:green)	1

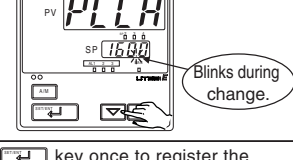
<p>(1) Bring the operating display into view (appears at power on).</p>  <p>Displays PV. Displays target setpoint.</p>	<p>(6) Press the  key several times to display the menu "PCMD" (PV color mode).</p>  <p>Displays parameter "PCMD"</p>
<p>(2) Press the  key for more than 3 seconds to call up the menu "OP.PA."</p>  <p>Displays menu "OP.PA."</p>	<p>(7) Press the  key or  key to display the required setpoint. The figure below shows an example of setting Link to alarm 1 mode.</p>  <p>Blinks during change</p>
<p>(3) Press the  key once to display the menu "STUP."</p>  <p>Displays menu "STUP"</p>	<p>(8) Press the  key once to register the setpoint.</p> <p>If PCMD = 6, 7, 8 or 9, also set the relating parameters PCCH (High limit for PV color change) and PCCL (Low limit for PV color change).</p> 
<p>(4) Press the  key once to display the parameter "PWD."</p> 	<p>(9) Press the  key for more than 3 seconds. This returns you to the display shown at power-on (figure blow).</p>  <p>Displays PV. Displays target setpoint.</p>
<p>(5) Press the  key once to display the menu "FUNC."</p>  <p>Displays menu "FUNC"</p>	

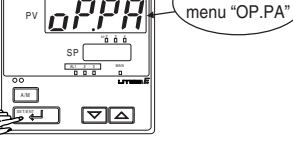
■ Setting the High Limit and Low limit for PV Color Change

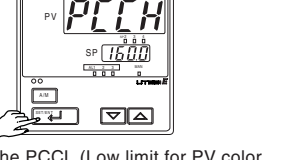
The following operating procedure describes an example of changing PV display color by PV limit(s). Set the High limit and/or the Low limit for PV color change.

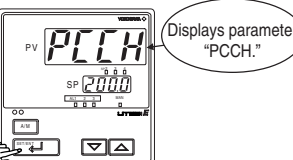
Parameter Symbol	Name of Parameter	Setting Range	Initial Value
PCCH (PCCH)	High limit for PV color change	When PCMD (PV color mode parameter) = 6 or 7: -100.0 to 100.0 % of PV input range.	When PCMD = 6 or 7: PCCH:100.0 %, PCCL:0.0 %
PCCL (PCCL)	Low limit for PV color change	When PCMD (PV color mode parameter) = 8 or 9: -100.0 to 100.0 % of PV input range span.	When PCMD = 8 or 9: PCCH and PCCL:1.0 %

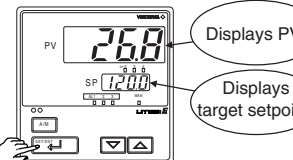
<p>(1) Bring the operating display into view (appears at power-on).</p>  <p>Displays PV. Displays target setpoint.</p>	<p>(4) Press the  key or  key to display the required setpoint.</p>  <p>Blinks during change.</p>
<p>(2) Press the  key for more than 3 seconds to call up the menu "OP.PA."</p>  <p>Displays menu "OP.PA"</p>	<p>(5) Press the  key once to register the setpoint.</p>  <p>Also set the PCCL (Low limit for PV color change parameter) that follows this setup.</p>
<p>(3) Press the  key several times to display the parameter "PCCH."</p>  <p>Displays parameter "PCCH."</p>	<p>(6) Press the  key for more than 3 seconds. This returns you to the display shown at power-on (figure below).</p>  <p>Displays PV. Displays target setpoint.</p>

Functions of Active Color PV Display

This part describes the functions of "Active Color PV Display." PV display color is changed by the following four actions.

PV display color is selectable from red-to-green or green-to-red changing action, or fixed color.

- Link to alarm 1 mode (when PCMD = 2, 3) (Setting example-1)

Link to alarm 1 and 2 mode (when PCMD = 4, 5) is the same. When either of the alarms occurs, the display color is changed.

- SP deviation mode (when PCMD = 8, 9) (Setting example-2)

- PV limit mode (when PCMD = 6, 7) (Setting example-3)

- Fixed color mode (when PCMD = 0, 1) (Setting example-4)

Setting Example-1 : Link to Alarm

Works linking to alarm 1.

Set "PV high limit alarm" for alarm-1 type, and "80°C" for alarm-1 setpoint.

If PCMD (PV color mode parameter) = 2, PV display color is changed from green to red

when PV input value exceeds alarm-1 setpoint.

The red-to-green changing action is selectable.

Setting parameters :

PCMD (PV color mode parameter) = 2

AL1 (Alarm-1 type parameter) = 1

A1 (Alarm-1 setpoint parameter) = 80°C

HY1 (Alarm-1 hysteresis parameter) = 5°C

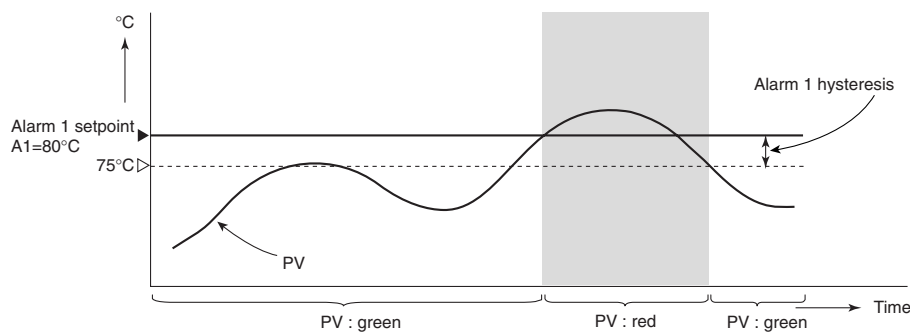

Setting Example-3 : Link to PV

Set the high limit "70°C" for PCCH, and the low limit "20°C" for PCCL.

PV display color is changed from green to red when PV input value is out of the range.

The red-to-green changing action is selectable.

Setting parameters :

PCMD (PV color mode parameter) = 6

PCCH (High limit for PV color change parameter) = 70°C

PCCL (Low limit for PV color change parameter) = 20°C

Hysteresis fixed to 0.25% is inserted where PV display color is changed.

In the example below, where changed from red to green.

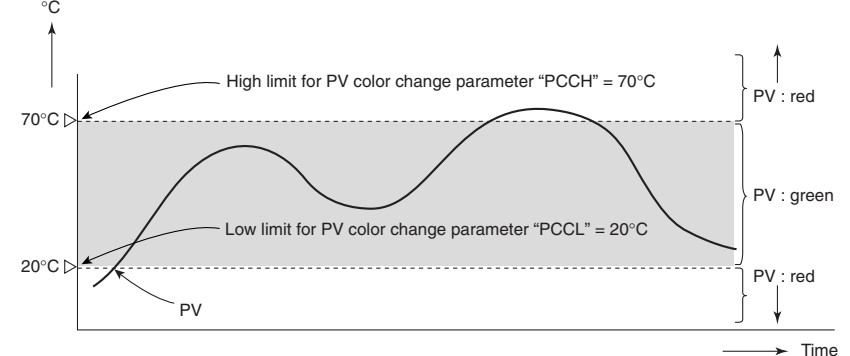

Setting Example-2 : Change by Deviation

Set the high limit deviation band "10°C" for PCCH and low limit deviation band "5°C" for PCCL,

for the current setpoint "50°C."

PV display color is changed from green to red when PV input value is out of the deviation.

The red-to-green changing action is selectable.

Setting parameters :

PCMD (PV color mode parameter) = 8

PCCH (High limit for PV color change parameter) = 10°C

PCCL (Low limit for PV color change parameter) = 5°C

Hysteresis fixed to 0.25% is inserted where PV display color is changed.

In the example below, where changed from red to green.

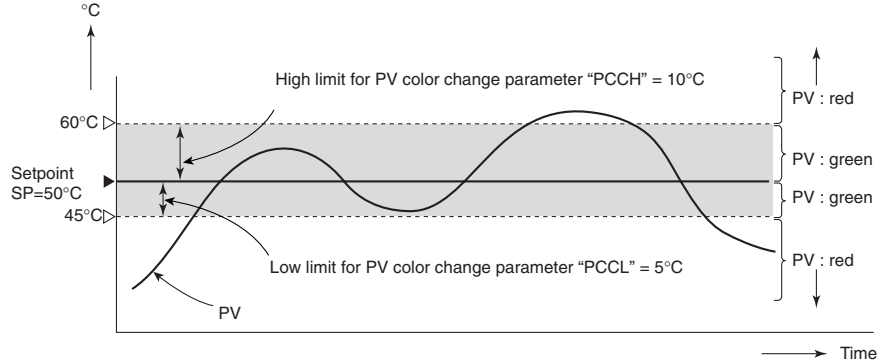

Setting Example-4 : Fixed in Red or Green

Fix the PV display color in green. Setting of Fixed in red mode is also possible.

Setting parameter :

PCMD (PV color mode parameter) = 0

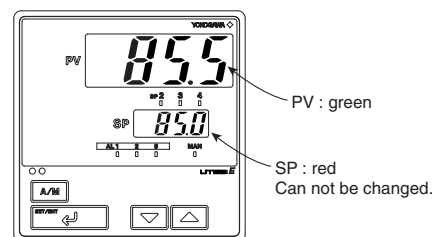

External RJC

The external RJC is not a compensation function built in a controller but a compensation function working outside the controller.

The external RJC is used when the input is thermocouple, and RJC=OFF.

Using external RJC makes the accuracy of RJC higher and shortens the compensating wire.

Parameter Symbol	Name of Parameter	Setting Range	Initial Value
ERJC (ERJC)	External RJC setpoint	-50.0 to 50.0°C, -58.0 to 122.0°F For thermocouple input, temperature compensation value outside the controller can be set. Available only when RJC=OFF.	0.0°C 32.0°F

